

MODEL: PTP - SERIES

- Powered by the reliable Ingersoll Rand (IR) Air Motor
- Torque output is consistently repeatable
- Steel adaption plate enables tool to be used underground
- Heat treated and hardened hex drive for superior longevity
- All models include a FRL & 12' air hose
- Support handle supplied with models PTP35 and above
- Accuracy level of +/- 5%
- Includes standard reaction arm
- Comes with convenient carry case
- Two Year Manufacturers Warranty*



		PTP10	PTP18	PTP22	PTP35	PTP45	PTP55	PTP75	PTP100	PTP120
Max. Torque	Nm	1107	1830	2175	3539	4500	5727	7703	11920	12713
	ft/lbs	816	1350	1604	2610	3319	4224	5681	8792	9377
Min. Torque	Nm	120	174	191	696	1113	1870	1987	3847	4216
	ft/lbs	89	128	141	513	821	1379	1466	2837	3110
Air Pressure (bar)	Min.	1	1	1	1.5	1.5	2	2	2	2
	Max.	6	6	6	6	6	6	6	6	6
Square Drive (S)		¾"	1"	1"	1"	1"	1½"	1½"	1½"	1½"
A (mm)		285	312	312	346	367	385	392	411	411
B (mm)		175	202	202	236	257	275	282	301	301
C (mm)		195	195	195	195	195	195	195	195	195
D (mm)		74	77	77	81	88	113	120	128	128
Weight (kg) **		5.2	6.2	6.2	7.8	9.4	14.3	15.8	19	19

** Does not include reaction arm

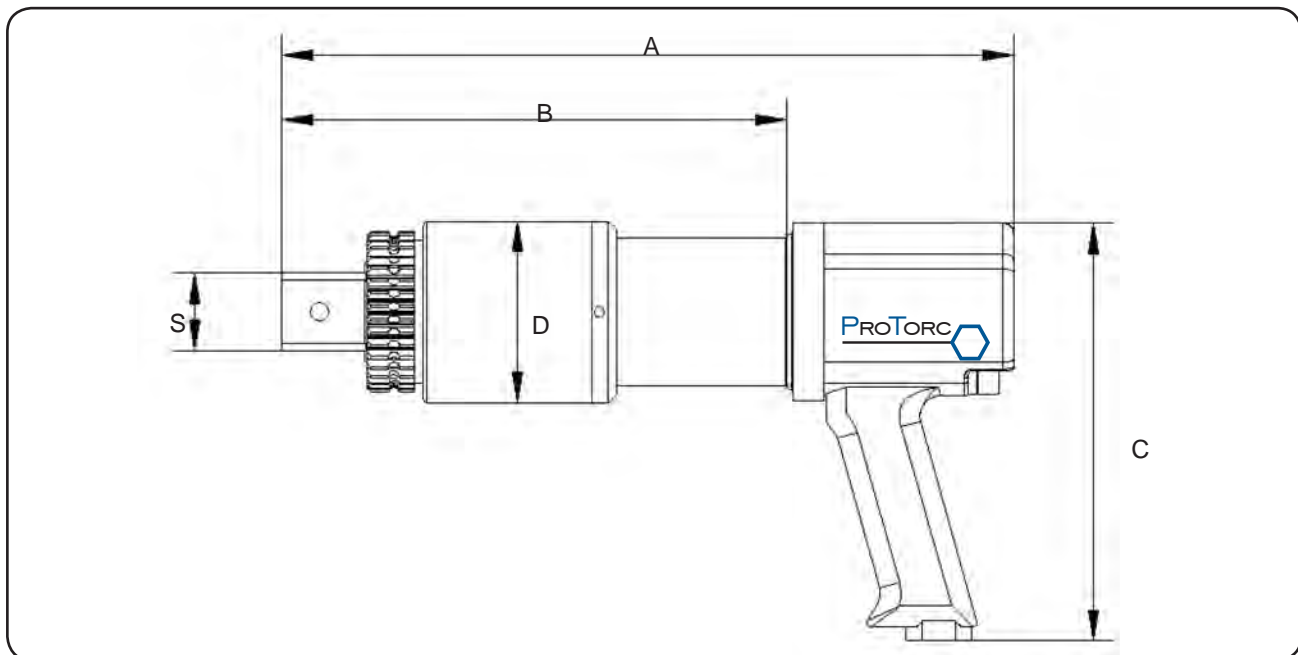

* Conditions apply - contact ProTorc for more information