

MODEL: HP-SERIES

- 100T pulling capacity
- Trolley mounted
- Single and 3 phase available

FEATURES

- Air/Hydraulic height adjustment
- Metered flow for precise speed control
- Double acting system for safe opening and closing of jaws
- Self centering design
- 2 or 3 jaw capabilities
- 5° up/down swivel adjustment for precise positioning

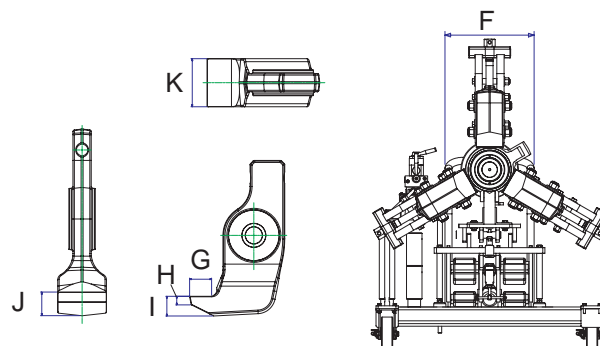
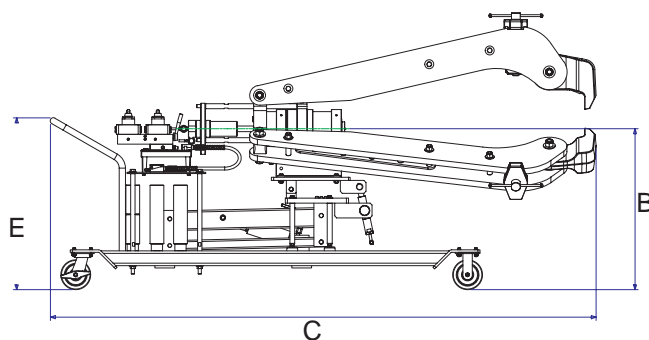

SPECIFICATIONS

Model	Stroke (mm)	Capacity (Ton)	A Min/Max (mm)	B Min/Max (mm)	C Min/Max (mm)	D (mm)	E (mm)	F (mm)	G (mm)	H (mm)	I (mm)	J (mm)	K (mm)	Weight (kg)	Pump
HP1003-220	270	100	1030-1980	817-1330	2390-2790	1025	873	402	65	25	58	58	120	1150	PED065
HP1003-380	270	100	1030-1980	817-1330	2390-2790	1025	873	402	65	25	58	58	120	1185	PED195

PULLER EXTENSIONS

Model	A (mm)	B (mm)	QTY
1B12020	70	150	2
1B12021	70	300	2

